

# Сирены сверхмощные многотональные WERMA 142 (120 дБ)

## Технические характеристики



Архангельск (8182)63-90-72  
Астана (7172)727-132  
Астрахань (8512)99-46-04  
Барнаул (3852)73-04-60  
Белгород (4722)40-23-64  
Брянск (4832)59-03-52  
Владивосток (423)249-28-31  
Волгоград (844)278-03-48  
Вологда (8172)26-41-59  
Воронеж (473)204-51-73  
Екатеринбург (343)384-55-89  
Иваново (4932)77-34-06

Ижевск (3412)26-03-58  
Иркутск (395)279-98-46  
Казань (843)206-01-48  
Калининград (4012)72-03-81  
Калуга (4842)92-23-67  
Кемерово (3842)65-04-62  
Киров (8332)68-02-04  
Краснодар (861)203-40-90  
Красноярск (391)204-63-61  
Курск (4712)77-13-04  
Липецк (4742)52-20-81  
Россия (495)268-04-70

Магнитогорск (3519)55-03-13  
Москва (495)268-04-70  
Мурманск (8152)59-64-93  
Набережные Челны (8552)20-53-41  
Нижний Новгород (831)429-08-12  
Новокузнецк (3843)20-46-81  
Новосибирск (383)227-86-73  
Омск (3812)21-46-40  
Орел (4862)44-53-42  
Оренбург (3532)37-68-04  
Пенза (8412)22-31-16  
Киргизия (996)312-96-26-47

Пермь (342)205-81-47  
Ростов-на-Дону (863)308-18-15  
Рязань (4912)46-61-64  
Самара (846)206-03-16  
Санкт-Петербург (812)309-46-40  
Саратов (845)249-38-78  
Севастополь (8692)22-31-93  
Симферополь (3652)67-13-56  
Смоленск (4812)29-41-54  
Сочи (862)225-72-31  
Ставрополь (8652)20-65-13  
Казахстан (772)734-952-31

Сургут (3462)77-98-35  
Тверь (4822)63-31-35  
Томск (3822)98-41-53  
Тула (4872)74-02-29  
Тюмень (3452)66-21-18  
Ульяновск (8422)24-23-59  
Уфа (347)229-48-12  
Хабаровск (4212)92-98-04  
Челябинск (351)202-03-61  
Череповец (8202)49-02-64  
Ярославль (4852)69-52-93

Единый адрес для всех регионов: [wme@nt-rt.ru](mailto:wme@nt-rt.ru) | [www.werma.nt-rt.ru](http://www.werma.nt-rt.ru)

# Heavy Duty Multi-Tone Sounder

## Your benefits

The robust housings of WERMA Heavy Duty Multi-Tone Sounders are particularly well-suited for use in public areas or in harsh industrial environments. Versions with an aluminium housing and separate certification (German Lloyd) are available for marine applications.

- Ideal in extremely noisy environments and over long distances
- Many application options with up to 42 tones
- Up to 3 tones can be externally triggered for the escalation of signals
- Includes standardised tones (including those used in fire alarms)

## Typical applications

Signalling of faults and alarms

- outdoors in extreme conditions
- in larger industrial plants
- in maritime applications

## Installation options

- Wall mounting

## Features

- High protection rating up to IP67
- Multi-voltage versions allow multiple applications with a single device



Signalisation index				
Audible	139	141	142	129
Multi-Tone Sounder	6	8	10	8



# 142 Electronic Multi-Tone Sounder (120 dB)



## ① TECHNICAL SPECIFICATIONS/ORDER SPECIFICATIONS:

Dimensions (L x H x W):	168 mm x 168 mm x 155 mm	
Housing:	PC/ABS-Blend	
Connection:	Screw terminal 0.5 - 2.5 mm <sup>2</sup>	
Cable entry:	Cable gland M20 x 1.5 mm (not included in assembly)	
Tone types and frequencies:	Selectable via DIP switch, see table on page 197	
Voltage:	18-30 V DC	115/230 V AC
Current consumption:	450 mA	130 mA (115 V) / 65 mA (230 V)
red	<b>142 000 55</b>	<b>142 000 68</b>
grey	<b>142 100 55</b>	<b>142 100 68</b>

## ✂ ACCESSORIES:

Cable gland M20 x 1.5 mm	<b>975 444 01</b>
--------------------------	-------------------

## ↔ TECHNICAL DIAGRAM:

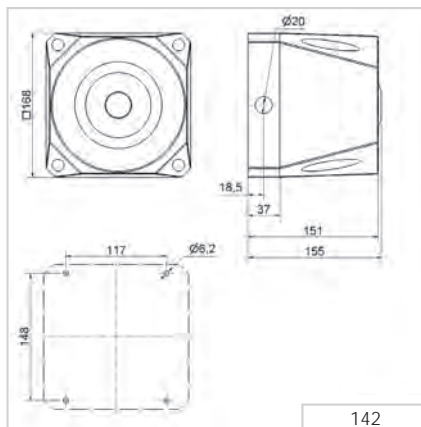

### Signalisation index

Multi-tone sounder **10**



142 X00 68



142 X00 55

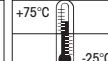

# 142 Tone table

The 142 Multi-Tone Sounder offers a large choice of internationally recognised signal tones for the widest spectrum of applications. The first two tones can be freely chosen. The third tone is paired with the second tone.

🎵 TONE TYPES AND FREQUENCIES:				
Tone 1+2 No.	Tone type	Description	Output (dBA)	Tone 3
1	alternating 800/970 Hz in 2 Hz stroke (250 ms-250 ms)		120	14
2	rising 800/970 Hz in 7 Hz stroke (7/s)		120	14
3	rising 800/970 Hz in 1 Hz stroke (1/s)		120	14
4	continuous 2,850 Hz		111	9
5	rising 2,400-2,850 Hz in 7 Hz stroke		109	4
6	rising 2,400-2,850 Hz in 1 Hz stroke		110	4
7	500-1,200 Hz rising in 3 sec., 0.5 sec. OFF	Slow Whoop Holland	119	14
8	falling 1,200-500 Hz in 1 Hz stroke	DIN/PFEER (PAPA), DIN 33404-3, VDS tested	119	14
9	alternating 2,400/2,850 Hz in 2 Hz stroke (250 ms-250 ms)		119	14
10	pulse 970 Hz in 0.5 Hz stroke (1 sec. ON / 1 sec. OFF)	PFEER Alarm	113	4
11	alternating 800/970 Hz in 1 Hz stroke (500 ms-500 ms)		117	14
12	pulse 2,850 Hz in 0.5 Hz stroke (1 sec. ON / 1 sec. OFF)		118	144
13	970 Hz pulse: 0.25 sec. ON / 1 sec. OFF		112	14
14	continuous 970 Hz	PFEER - Toxic gas	117	8
15	554 Hz/100 ms alternating 440 Hz/400 ms	French alarm signal AFNOR NFS 32 S 32-001	118	14
16	660 Hz pulse: 150 ms ON, 150 ms. OFF	Swedish alarm signal	115	14
17	660 Hz pulse: 1.8 sec. ON, 1.8 sec. OFF	Swedish alarm signal	114	14
18	660 Hz pulse: 6.5 sec. ON, 13 sec. OFF	Swedish alarm signal	115	14
19	continuous 660 Hz	Swedish alarm signal	116	1
20	alternating 554/440 Hz in 0.5 Hz stroke (1 sec. ON / 1 sec. OFF)	Swedish alarm signal	115	19
21	pulse 660 Hz in 1 Hz stroke (500 ms-500 ms)	Swedish alarm signal	115	4
22	pulse 2,850 Hz in 4 Hz stroke (150 ms ON / 100 ms OFF)		110	4
23	rising 800-970 Hz in 50 Hz stroke		117	14
24	rising 2,400-2,850 Hz in 50 Hz stroke		110	4
25	970 Hz pulse: 3 x 500 ms. ON, 500 ms OFF, break 1.5 sec.	ISO 8201 / US Temporal	118	14
26	2,850 Hz pulse: 3 x 500 ms. ON, 500 ms OFF, break 1.5 sec.	ISO 8201 / US Temporal	112	4
27	continuous 4,000 Hz		105	6
28	alternating 800/970 Hz in 2 Hz stroke (250 ms-250 ms)		118	14
29	alternating 990/650 Hz in 2 Hz stroke (250 ms-250 ms)		117	14
30	alternating 510/610 Hz in 2 Hz stroke (250 ms-250 ms)		116	14
31	rising 300-1,200 Hz in 1 Hz stroke		118	14
32	continuous Bell		117	3
33	continuous Bell: 3x500 ms. Pulse, 1.5 sec. Silence, then repeat	Bell / US Temporal	117	14
34	alternating 1,000/2,000 Hz in 1 Hz stroke (500 ms-500 ms)	Singapore	115	4
35	pulse 420 Hz (0,625 sec.)	Australian alarm signal	118	14
36	500-1,200 Hz rising in 3,75 sec., then 0,25 sec. OFF	Australian alarm signal (Evacuation)	117	14
37	rising 1,400-1,600 Hz in 1 sec., falling in 0.5 sec.	NF C 48-265	116	14
38	500-1,200 Hz rising and falling 3 sec.	Siren	117	14
39	pulse 720 Hz: 0.7 sec. ON, 0.3 sec. OFF	German industrial alarm	118	14
40	rising 422-775 Hz in 0.85 sec., 1 sec. silence, then repeat	NFPA Whoop	118	14
41	continuous 470 Hz	Horn (USA)	114	3
42	continuous 370 Hz	Air Horn (USA)	113	3



<b>Архангельск</b> (8182)63-90-72	<b>Ижевск</b> (3412)26-03-58	<b>Магнитогорск</b> (3519)55-03-13	<b>Пермь</b> (342)205-81-47	<b>Сургут</b> (3462)77-98-35
<b>Астана</b> (7172)727-132	<b>Иркутск</b> (395)279-98-46	<b>Москва</b> (495)268-04-70	<b>Ростов-на-Дону</b> (863)308-18-15	<b>Тверь</b> (4822)63-31-35
<b>Астрахань</b> (8512)99-46-04	<b>Казань</b> (843)206-01-48	<b>Мурманск</b> (8152)59-64-93	<b>Рязань</b> (4912)46-61-64	<b>Томск</b> (3822)98-41-53
<b>Барнаул</b> (3852)73-04-60	<b>Калининград</b> (4012)72-03-81	<b>Набережные Челны</b> (8552)20-53-41	<b>Самара</b> (846)206-03-16	<b>Тула</b> (4872)74-02-29
<b>Белгород</b> (4722)40-23-64	<b>Калуга</b> (4842)92-23-67	<b>Нижний Новгород</b> (831)429-08-12	<b>Санкт-Петербург</b> (812)309-46-40	<b>Тюмень</b> (3452)66-21-18
<b>Брянск</b> (4832)59-03-52	<b>Кемерово</b> (3842)65-04-62	<b>Новокузнецк</b> (3843)20-46-81	<b>Саратов</b> (845)249-38-78	<b>Ульяновск</b> (8422)24-23-59
<b>Владивосток</b> (423)249-28-31	<b>Киров</b> (8332)68-02-04	<b>Новосибирск</b> (383)227-86-73	<b>Севастополь</b> (8692)22-31-93	<b>Уфа</b> (347)229-48-12
<b>Волгоград</b> (844)278-03-48	<b>Краснодар</b> (861)203-40-90	<b>Омск</b> (3812)21-46-40	<b>Симферополь</b> (3652)67-13-56	<b>Хабаровск</b> (4212)92-98-04
<b>Вологда</b> (8172)26-41-59	<b>Красноярск</b> (391)204-63-61	<b>Орел</b> (4862)44-53-42	<b>Смоленск</b> (4812)29-41-54	<b>Челябинск</b> (351)202-03-61
<b>Воронеж</b> (473)204-51-73	<b>Курск</b> (4712)77-13-04	<b>Оренбург</b> (3532)37-68-04	<b>Сочи</b> (862)225-72-31	<b>Череповец</b> (8202)49-02-64
<b>Екатеринбург</b> (343)384-55-89	<b>Липецк</b> (4742)52-20-81	<b>Пенза</b> (8412)22-31-16	<b>Ставрополь</b> (8652)20-65-13	<b>Ярославль</b> (4852)69-52-93
<b>Иваново</b> (4932)77-34-06	<b>Россия</b> (495)268-04-70	<b>Киргизия</b> (996)312-96-26-47	<b>Казахстан</b> (772)734-952-31	

**Единый адрес для всех регионов: [wme@nt-rt.ru](mailto:wme@nt-rt.ru) | [www.wema.nt-rt.ru](http://www.wema.nt-rt.ru)**